

THE STRONG BUCKET EXTREME CONDITIONS



HALF PIPE GROUP

SEMI-TRAILER
INSIDE THE HALF-PIPE



TECHNICAL CHARACTERISTICS OF THE HALF-PIPE TIPPER SEMI-TRAILER



**HALF PIPE
GROUP**

TOTAL LENGTH	9.730 mm
TOTAL WIDTH	2.550 mm
SADDLE HEIGHT 1.300 mm	
VOLUME	24m ²
AXLE	Disc or drum brakes with a load capacity of 3x12000 kg from Reis, BPW or SAF.
LIFT AXLE	Lift axle system that reduces tire wear and simplifies maneuvering during U-turns
CHASSIS STRUCTURE	Built exclusively for Reis, made of top quality steel. I-section beams produced by submerged arc welding. Adapted to EEC 98/91 standards.
BRAKING SYSTEM	Fitted with an RSS automatic load sensing valve and suitable for 71/320 EEC and 2002/78 CE standards.
BEQUILLES	Reis, QRC, JOST or SAF brand mechanical landing gear with a load capacity of 24 tons.
KING PIN	2" king pin detachable from below (8 mounting bolts) manufactured by SAE to 94/20 EEC standard.
REAR BUMPER	Removable rear bumper suitable for 70/221/ AT standard.
SUSPENSION PNEUMATIC	Trailer height adjustment system and shock absorber to limit the movements of the axle parabolic Z springs.
ELECTRICAL EQUIPMENT AND LIGHTING	3 yellow lights placed on the sides, parking lights at the rear of the vehicle, license plate lighting, reflective triangles, fireproof electrical system, 2 7-pin electrical outlets, protective grill on the rear lights
TOOLBOX	Plastic tool box with a dimension of 70x60x50 cm.
WATER RESERVOIR	30 LT plastic water tank.
TIRES AND RIMS	6+1 tires in 385/65 R 22.5 steel rims
SUPERSTRUCTURE	4.5mm(Hardox) base and on the rear door the face of the side walls is 4mm wear resistant steel.
HYDRAULIC SYSTEM	5-stage telescopic cylinder, raises and lowers quickly, system prevents the semi-trailer from lifting automatically
MANOMETER	axle pressure barometer indicator versus airbag pressure
MUDGUARD	2 galvanized steel fenders with plastic edges

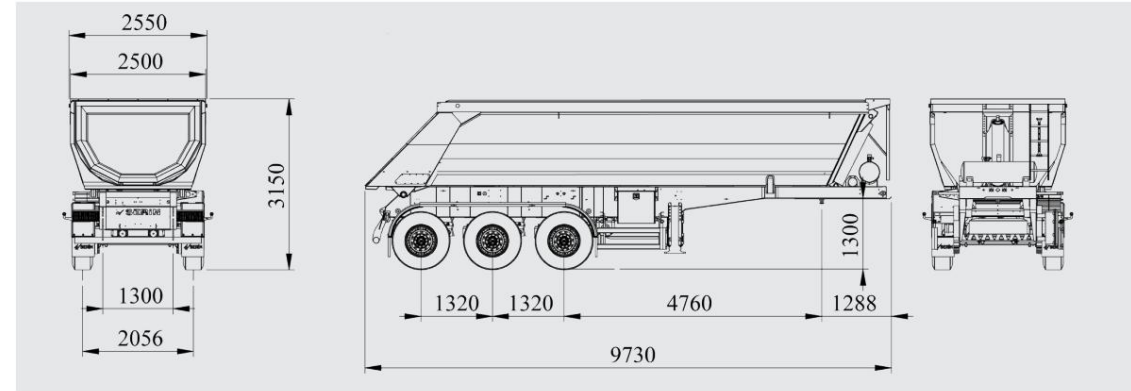

OPTIONAL

IVMT	Electronic suspension control system.
SMART BOARD	
Display located near the axle group which indicates and controls the load rate on each axle.	
Airbag pressure control Lift axle system that reduces tire wear and simplifies maneuvering when making U-turns.	
Daily service and registration of total kilometers traveled.	
Devices recording road conditions and circumstances after vehicle use.	
ECAS	Braking system.
Electric pump	



SERIN AUTOMOTIVE INC.

Buyukkayacik Mah. Konya OSB Evrenköy Cad. 3 Nolu Sokak No:12 42100 Selçuklu / Konya T|
+90,332 239 06 10 | F| +90,332 239 06 13 | sales@reistreyler.com.tr



/reistreyler

REISTREYLER.COM.TR



TSEK



TÜV AUSTRIA

TÜV AUSTRIA

TÜV AUSTRIA